



**HOMOLOGATION PROCEDURES
FOR MANUFACTURERS
VOLLEYBALLS & BEACH VOLLEYBALLS**

**FIVB World, Continental & National
Volleyball and Beach Volleyball Competitions**

FÉDÉRATION INTERNATIONALE DE VOLLEYBALL

Edouard-Sandoz 2-4 CH-1006 Lausanne - SWITZERLAND

Tel : +41 (21) 345 3535 Fax : +41 (21) 345 3545 Website : www.fivb.org

Dear Sir / Madame,

We thank you for your inquiry concerning FIVB homologation.

We draw your attention to the fact that only ball producers (manufacturers) can submit a request for a ball homologation. We are pleased to enclose our Terms & Conditions for Homologation of ball as well as an Application Form (H1).

If you are interested to submit your product, you have to send us the form H1 duly completed with a letter of recommendation from the National Volleyball Federation of the country, where the ball is produced; We would also like to point out that the FIVB only homologates a specific brand name and never company's products in general.

As soon as we receive your payment of CHF 4,000. - (test fees for the scientific laboratory) on our account number:

BIC Code (SWIFT Address): UBSWCHZH8OA
Bank Address:

UBS AG
Place St-François 16
Case postale
CH-1002 Lausanne
Switzerland

Bank clearing: 0243

ACCOUNT:
Account CHF: 0243-146146.01K - IBAN: CH710024324314614601K

Remark: Ball test

The application form H1 duly completed and the recommendation letters, we will send you the addresses of our testers and laboratories where manufacturer will have to send 12 balls for the scientific laboratory testing purposes. For the physical players test run by the FIVB Technical Commission members 20 balls in total must be submitted and 4 FIVB testers will receive 5 balls each.

A homologation agreement with your company will be signed by the FIVB, once the final reports of the tests have been received by the Technical Department and validated by the FIVB Technical Commission that recommends the ball for formal approval (about 3 months). When the testing process is over and when all requirements have been met the FIVB President signs the contract and the homologation certificate.

Please do not hesitate to contact us if you have any further queries.

**With best regards,
Fédération Internationale De Volleyball**

**Helgi THORSTEINSSON,
TECHNICAL DIRECTOR**
technical@fivb.org

*Encl.: Terms and conditions
Application form H1
Standards for volleyballs*

INDEX

FIVB HOMOLOGATION PROCEDURES FOR VOLLEYBALLS AND BEACH VOLLEYBALLS

Cover letter

Introduction.....	3
Homologated Sports Material & Equipment.....	4
Terms and Conditions.....	5
Application Form H-1.....	8
Testing parameters for synthetic Volleyball balls.....	9
FIVB Approved Volleyball.....	10
Testing parameters for synthetic Beach Volleyball balls.....	11
FIVB Approved Beach Volleyball.....	12
FIVB corporate logo and ball stamps.....	13

INTRODUCTION

This document is produced by the FIVB for FIVB, World and Official Competitions (other specific conditions may apply for the Olympic Games as per the Olympic Charter).

Sections in this document include:

1. Homologation Procedures for Volleyball and Beach Volleyball balls
2. Definition on FIVB Competitions
3. Homologated Sports Material

DEFINITION OF FIVB COMPETITIONS

Please note that the definition for FIVB Competitions can be found in the FIVB Sports Regulations, Chapter I, Article 2, subsections. 2.2, 2.2.2 and 2.2.3 on FIVB Competitions, 2.3 on World Competitions, 2.4 on Official Competitions, 2.5 on Recognized Competitions, 2.6 on Registered Competitions

http://www.fivb.org/EN/FIVB/Document/Legal/FIVB_Sports_Regulations_en_20130515.pdf

FIVB Competitions include:

World Championships, World Championships Qualifying Tournaments, World Olympic Qualifying Tournaments, World Cups, Men's Under 21 and Women's Under 20 Junior World Championships and their qualifying tournaments, Boys' Under 19 and Girls' Under 18 and their qualifying tournaments and World Grand Champions Cup, Height Limit World Championships (Men U-185, Women U-175).

World League, World Grand Prix, Men's Club World Championship, World Gala, World Super Challenge and Age Competition (U16, U23 etc.).

World Competitions include:

Olympic Games (the Olympic Charter also applies), Youth Olympic Games, Military World Games, Universiade and Master Games.

Official Competitions include:

Continental Senior Championships, Continental Men's and Women's Junior Championships, Continental Boys' and Girls' Youth Championships, Height Limit Continental Championships (Men U-185, Women U-175), Continental Games and Regional Games.

Recognized Competitions include:

The governing body is the organizing National Federation. It drafts, in consultation with the sponsors, the Specific Competition Regulations and conditions which are to be approved by the FIVB. The conditions include specifications regarding prize money, title sponsor and commercialization.

HOMOLOGATED SPORTS MATERIALS

The use of homologated sports materials is mandatory for all FIVB World and Official Competitions, as well as National or League Championships.

Sports Materials are articles necessary for the practice of Volleyball that are not deemed to be personal items.

Homologated Sports Materials are sports materials declared by the FIVB as being in accordance with the Official Volleyball Rules and thus declared to be in accordance with FIVB international standards.

http://www.fivb.org/EN/Technical-Coach/Document/FIVB_Technical_Homologated_Equipment_01112013.pdf

1.1 SYNTHETIC FLOORS

For 2013-2016 Taraflex Sport M Evolution 7mm and Taraflex Sport M Performance 9mm by GERFLOR is the FIVB Approved and the homologated sports floor for FIVB competitions.

Taraflex by GERFLOR is the exclusive floor covering for all FIVB World Competitions: World League, World Grand Prix, World Championships and other official competitions, incl. OG 2016.

If the subfloor is wood or synthetic we recommend using Taraflex Sport M Evolution Coral 6146 for the center court and Taraflex Sport M Evolution Teal 6431 for the surrounding area. If the subfloor is concrete or similar we recommend using Taraflex Sport M Performance Coral 6146 for the center court and Taraflex Sport M Performance Teal 6431 for the surrounding area.

1.2 BALLS

For 2013-2016, MIKASA Ball Type MVA-200 is the exclusive game ball for FIVB World Competitions and for the following FIVB Official Competitions: World League and World Grand Prix. For the period 2013 – 2016 only synthetic leather colored Volleyballs are approved as FIVB Approved Volleyball balls.

For 2013-2016, other FIVB APPROVED and homologated balls include:

Manufacturer	Model	Manufacturer	Model
MIKASA	MVA 200	NATIONMAN	Profit 9900
MIKASA	MVA 300	GALA	BV 5591S
MIKASA	VLS 300 / Beach	CAMBUCI	Penalty Pro 7.0
MOLTEN	V5M5000	QUINGDAO-SYNSHEEN	Star VB 225-34
MOLTEN	BV5000 / Beach		

Table 1

Note: For FIVB World Competitions, World League and World Grand Prix, ball trolleys, ball bags or related ball equipment must not display any advertising deemed by the FIVB to be in conflict with FIVB Exclusive Suppliers. Please also refer to 3.6 of the Advertising Guidelines: http://www.fivb.org/en/volleyball/Documents/FIVB_Volleyball_Sports_Material_Team_Equipment_and_Advertising_Guidelines_15.07.2012.r25%20.pdf

1.3 COURT EQUIPMENT

For 2013-2016, JINLING court equipment (including net posts, post protection, net antennae, nets and referees' chairs) is the official supplier for all FIVB World Competitions. Use of other court equipment for FIVB Official Competitions must be submitted for approval to the FIVB. For preliminary rounds of World League and World Grand Prix FIVB approved suppliers are authorized.

1.4 UNIFORMS

Only uniforms homologated by the FIVB are authorized in FIVB World and Official Competitions. Uniform and shoe suppliers homologated by the FIVB for the period 2013-2016 are as follows:

ADIDAS	Uniforms & Shoes	MEROOJ	Uniforms
ASICS	Uniforms & Shoes	MIKASA	Uniforms
DACAPO	Uniforms	MIZUNO	Uniforms
ERREA	Uniforms	NIKE	Shoes
GRANDSPORT	Uniforms	OLYMPIKUS	Uniforms & Shoes
MACRON	Uniforms	WALON	Uniforms & Shoes
		ZEUS	Uniforms

Table 2

TERMS AND CONDITIONS FOR FIVB HOMOLOGATION (APPROVAL) BALLS TO BE USED IN OFFICIAL VOLLEYBALL COMPETITIONS

Any **manufacturer** of Volleyball balls, wishing to obtain a world-wide valid certificate of official homologation for one or more of its products under official FIVB standards and quality controls may proceed as follows:

1. A duly completed application (FIVB form H-1) must be sent to:

Fédération Internationale de Volleyball
Eduouard-Sandoz 2-4 – 1006 Lausanne SWITZERLAND
Telephone: +41 (21) 345 35 35 - Fax: +41 (21) 345 35 45

Attention: FIVB Technical Commission
Mr. Helgi THORSTEINSSON, Technical Director

2. The following documents must be attached to the application form:

- 2.1 **For a ball manufacturer**, a letter of recommendation, signed by the National Volleyball Association of its country, stating that the ball proposed has been successfully used in local Volleyball tournaments organized by the Association. **If the production line and the company are not located in the same country, the manufacturer must also provide a letter of recommendation of the National Volleyball Association of the country where the factory is located. Each manufacturer can only produce one specific brand to be homologated by the FIVB.**

- 2.2 A copy of bank transfer order for the fixed amount for testing and laboratory fees for **each ball type** as follows:

For balls - CHF. 4,000.- (four thousand Swiss Francs).

Payments must be made to FIVB account:
ACCOUNT CHF: 0243-146146.01K - IBAN: CH710024324314614601K
UBS AG, Place St-François 16
Case postale, CH-1002 Lausanne
Switzerland

3. Once the documents and payment have been received in Lausanne, the Technical Department proceeds as follows:

- 3.1 The **manufacturer** of the balls will be forwarded a list of names and addresses of the persons and laboratories, to which he must submit the balls (max. 32) to be tested.
- 3.2 The manufacturer will be informed that he is obliged to send the **“test balls”** free of charge and duties, (air freight, insurance) stating in all documents **“SAMPLES WITH NO COMMERCIAL VALUE”**.

4. Once the test is completed:

- 4.1 The Technical Department will request to receive the reports from the testers and the results from the laboratories.
- 4.2 If the tests prove that the products **do not** meet FIVB standards:
 - a) The manufacturer will be informed on the test results.

- b) The Technical Department will inform the manufacturer that a second application is acceptable within the ensuing 12 months. *When the required improvements have been made* the manufacturer must send a new collection to be tested.
- c) After a 12-month delay, a new application is required with new payment for testing and laboratory fees.

4.3 **If the tests prove satisfactory:**

- a) When the product has been declared in line with FIVB requirement, the manufacturer proceeds to sign a maximum four-year contract with the FIVB for the official approval of its product and ratified by the Board of Administration.
- b) When the contract has been signed and the first yearly fee has been paid, the FIVB will issue a **CERTIFICATE OF OFFICIAL HOMOLOGATION** for each product approved.
- c) Together with the certificate the manufacturer will receive a model of the **FIVB Approved seal** with instructions for stamping or printing it on each unit of the approved product.

5. Ball manufacturers are obliged to obtain certificate for each type of ball they intend to market with the FIVB seal for approval. The types of ball subject to approval are :

FIVB Approved balls:

Size 5, 8 -18 panels, senior <u>Volleyball (color) synthetic:</u>	CHF. 60,000 per year
Size 5, 10 -18 panels, senior <u>Beach Volleyball (color):</u>	CHF. 40,000 per year

FIVB Inspected balls:

Size 5, 8 -18 panels, senior Volleyball (color) synthetic:	CHF. 12,500 per year
--	----------------------

FIVB Tested balls:

Size 5, Volleyball (color) synthetic:

Balls tested for FIVB standards. No stamps applied but direct cost for the tests applicable.

6. Up on signature of the contract: **The manufacturer** will be authorized to stamp or print its name or logo on each of the approved balls.

The following dimensions must not be exceeded:

Balls: height of letters 2.5cm x length of make 12 cm (30 sq. cm)

7. The FIVB logo may be printed or stamped once or two times on each of the approved products depending on panel construction, no less than 3 x 3 cm in size on balls and in proportion to the manufacturer's logo on other products. It should always be placed below and centrally to the manufacturer's name or logo strictly in accordance with the design and measurements provided by the FIVB. Each manufacturer must present the design to the FIVB for prior approval.

8. Contact details for the FIVB Testing laboratory in Switzerland:

EMPA
Materials Science & Technology
Mr. Ivo RECHSTEINER
Lerchenfeldstrasse 5
ST. GALLEN 9014
Switzerland

Tel: + 41 (71) 274 77 79
Fax: + 41 (71) 274 77 62
E-mail: ivo.rechsteiner@empa.ch
Website: www.empa.ch

9. FIVB active testers.

The FIVB Technical Department will provide the manufacturer with the names of the testers of the FIVB Technical Commission who will conduct the physical player's tests only after the fulfillment of the scientific laboratory tests.

FEDERATION INTERNATIONALE DE VOLLEYBALL H-1
APPLICATION FORM FOR THE OFFICIAL HOMOLOGATION OF BALLS,
UNIFORMS, SPORTS MATERIAL AND EQUIPMENT
(only for manufacturer)

Manufacturer's name : _____

Address : _____

Country : _____ Tel. : _____ Fax: _____ E-mail _____

PRODUCT IDENTIFICATION

(to be completed only by the manufacturer)

A. Category

Balls, type of :

- Indoor
- Beach
- School Mini
- Club Mini
- Recreational

Equipment, type of :

- Posts + Post Pads
- Net + Antennae
- Referees' Stand
- Scoreboard
- Shoes
- Uniforms
- Floor cover

B. Brand name : _____

C. Catalogue identification : _____

D. Other useful information : _____

Units produced per year : _____ **Price per unit approx. US\$** _____

- National Continental Worldwide

We, the undersigned, certify that we are the owners of the brand name of the product and that we intend to execute a max. 4 year contract with the FIVB for our product(s) recognition under FIVB standards.

Manufacturer :

(signature and stamp)

Date :

(Day - Month - Year)

Reception dates of : (for FIVB use only)

Application : _____
Samples : _____
Lab payment : _____
1st lab. result : _____
2nd lab result : _____
Board approval : _____

FIVB Signatures of approval

Technical Commission President

FIVB Manager

FIVB President

FIVB COMPETITION COLOR VOLLEYBALL (INDOOR)

LABORATORY REQUIREMENTS AND BALL STANDARDS FOR THE APPROVAL OF SYNTHETIC COLOR INDOOR VOLLEYBALL

1. Temperature in the laboratory: 20 – 25 degrees centigrade (20° - 25°C)
2. Minimum standard and range of test results.

2.1 **Ball size 5 for seniors Synthetic color indoor Volleyball:**

- A) Material: Synthetic leather (*Non-woven fabric + PU*).
- B) Number of Panels: Minimum 8 – Maximum 18
- C) Colors: Combination of: Min. 2 – Max. 3 colors** (*Ultra fine fiber structure*).
- D) Weight: 270 g \pm 10 g.
- E) Circumference: 66.0 \pm 1.0 cm.
- F) Impact power from 1 m height on Kistler Force Plate:
Range (387.5 – 402.5 N).
- G) Height of rebound from 1 m height on Kistler Force Plate:
Range (60.0 - 66.0 cm.)
- H) Endurance test in Endurance Test Machine :
Minimum number of times: Min. 10,000 repetitions at speed 50 km/h
- I) Pressure in the ball; 0.30 – 0.325 kg/cm² or 294.3 – 318.82 m. bar or hPa.

J) **Detection of use of banned Azo Colorants:**

Banned azo colorants are such colorants that may form one of the following amines of class MAK III A1 and MAK III A2 splitting up one or more azo groups.
Detection limit: 5 ppm.

- K) Test for Pentachlorophenol (PCP) and Tetrachlorophenol (TeCP)
(Test method according to DIN 53313) – No detection allowed

3. Diagram on design of the reflex plate and how endurance test is completed:

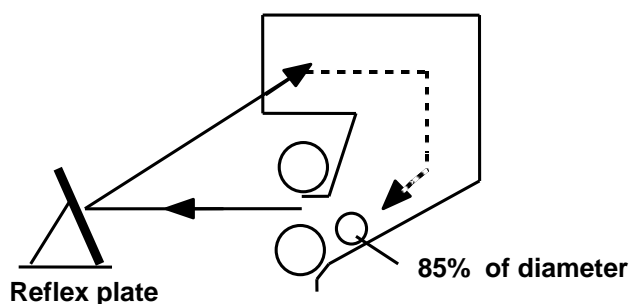

(Design on the reflex plate)

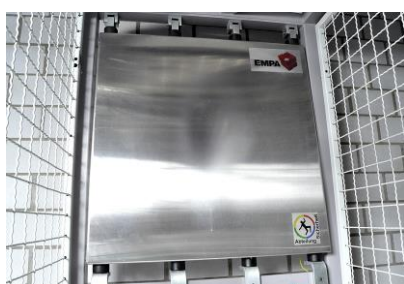
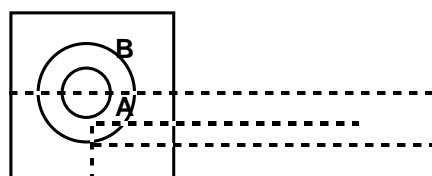

FIVB Official Colored Synthetic Volleyball ball Indoor

MIKASA MVA200

Panel and color construction:

Pantone colors: Blue 072C / Yellow 012C

OFFICIAL FIVB GAME BALL VOLLEYBALL

Front



Back



Side



The ball patterns are registered by Mikasa Corporation and cannot be used.

FIVB COMPETITION COLOR VOLLEYBALL (BEACH)

LABORATORY REQUIREMENTS AND BALL STANDARDS FOR THE APPROVAL OF BEACH VOLLEYBALL BALLS

1. Temperature in the laboratory: 20 – 25 degrees centigrade (20° -25° C)
2. Minimum standard and range of test results.

2.1 **Balls size 5, BEACH Volleyball, flexible material* (leather or similar), 10 to 18 panels:**

- A) Material: Man-made leather (*Non-woven fabric + PU*).
- B) Colors: **3 colors****.
- C) Weight: 270 g \pm 10 g.
- D) Circumference: 67.0 \pm 1.0 cm
- E) Impact power from 1 m height on Kistler Force Plate:
Range (290 – 360 N).
- F) Height of rebound from 1 m height on Kistler Force Plate:
Range (53.0 - 61.0 cm.)
Endurance test in Endurance Test Machine:
Minimum number of times: Min. 5,000 repetitions at speed 50 km/h.
Pressure in the ball; 0.225 kg/cm² or 221 M. bar or hPa.
Loss of pressure \leq 10% and sphericity required \leq 1.5%
- G) **Detection of use of Banned Azo Colorants:**
Banned azo colorants are such colorants that may form one of the following:
Amines of class MAK III A1 and MAK III A2 splitting up one or more azo groups.
Detection limit: 5 ppm.
- H) Test for Pentachlorophenol (PCP) and Tetrachlorophenol (TeCP)
Test method according to DIN 53313) - No Detection allowed

3. Diagram on design of the reflex plate and how endurance test is completed:

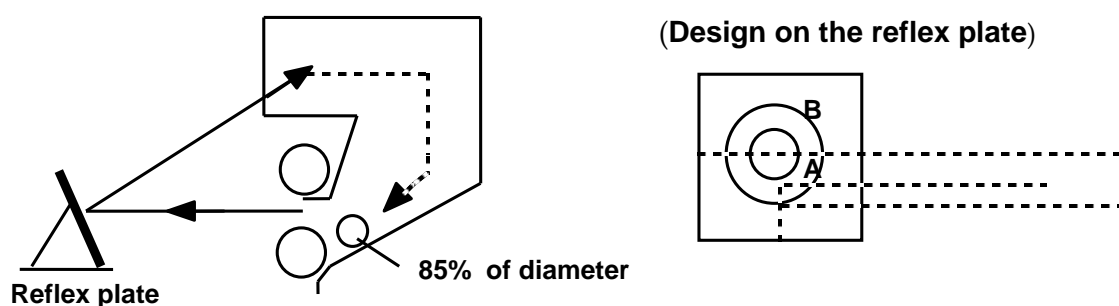

FIVB Official Colored Synthetic Beach Volleyball

Mikasa VLS 300

Colors FIVB Official Beach Volleyball ball:

Pantone colors: Blue 072C, Yellow 012C and White

FIVB GAME BALL BEACH VOLLEYBALL PATTERN

Front



Back



Panel color combination **and panel construction are shown** on the picture above.

The ball patterns are registered by Mikasa Corporation and cannot be used.

FIVB REGISTERED TRADEMARK AND OFFICIAL COLORS

The FIVB™, Fédération Internationale de Volleyball (Switzerland non-profit organization) and its corporate logo is a registered trademark. The use of the FIVB logo and the below approval stamps is strictly prohibited unless by the authorization of the FIVB.



FIVB APPROVED STAMP



FIVB INSPECTED STAMP

